

Resumo do aço

ACO	DIAM (mm)	C.TOTAL (m)	PESO + 10% (kg)
CA50	8.0	1	0.3
	8.0	496.4	215.4
	10.0	223.9	151.8
	12.5	29	29.6
	18.0	18.2	31.5
CA60	5.0	893.3	151.5
PESO TOTAL (kg)			
CA50		428.6	
CA60		151.5	

Volume de concreto (C-25) = 10.05 m³
Área de forma = 139.57 m²

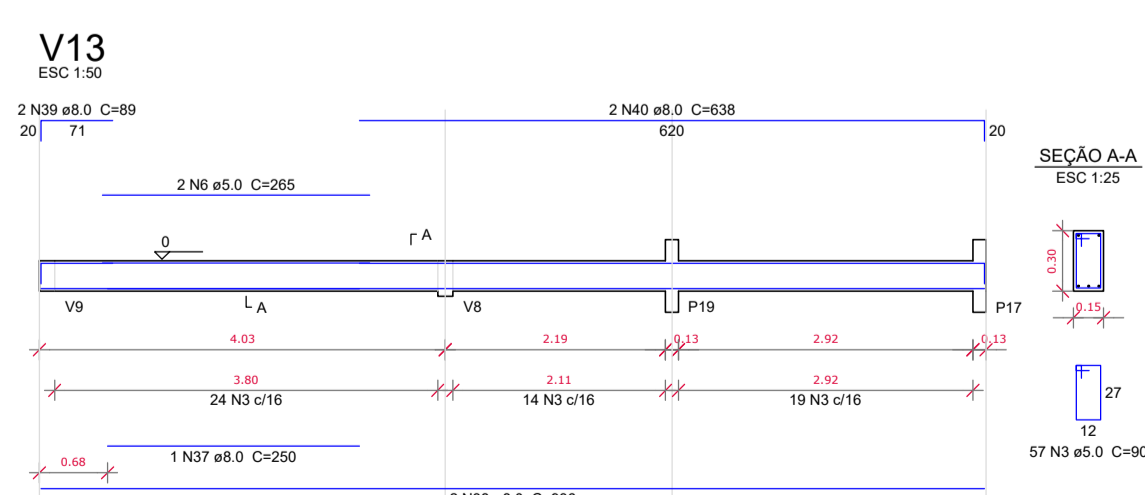
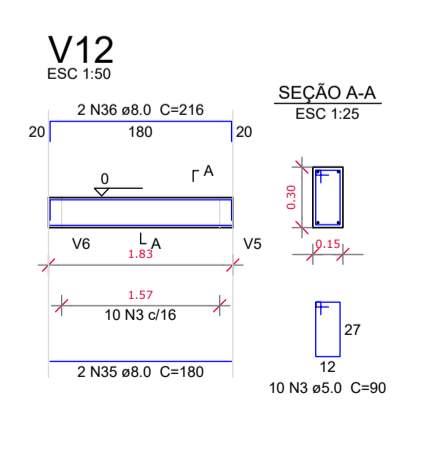
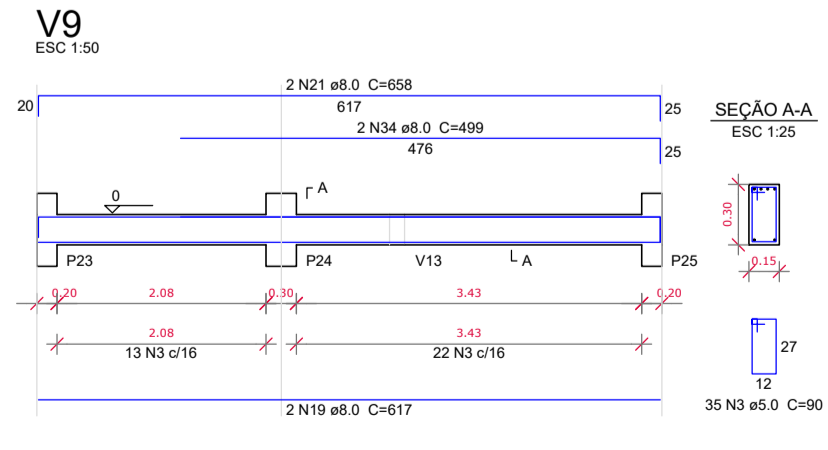

PROJETO PADRÃO - FNDE

MUNICÍPIO - UF: CAJATI-SP
PROPRIETÁRIO: PREFEITURA MUNICIPAL DE CAJATI
ENDEREÇO: ESTRADA TAKASHI FUKUDA, S/N - BAIRRO ABÓBORA - 11950-000



QUADRA COBERTA COM PALCO
BAIRRO ABÓBORA

COORDENAÇÃO Secretaria de Obras e Mobilidade Urbana	DETALHAMENTO DE ARMADURA DE VIGAS E PILARES	ESCALA INDICADAS	FRANCHA
REVISÃO BTS ENGENHARIA	ESCALA INDICADAS	DATA EMISSÃO OUTUBRO/2024	EST
FORMATO DESENHO			07/09